

# **SIMPLE ENGINE MECHANISM**

## **Final Assembly - Exploded View**

**Scale - 1:4**

**Created By - Jog Desai & Team**

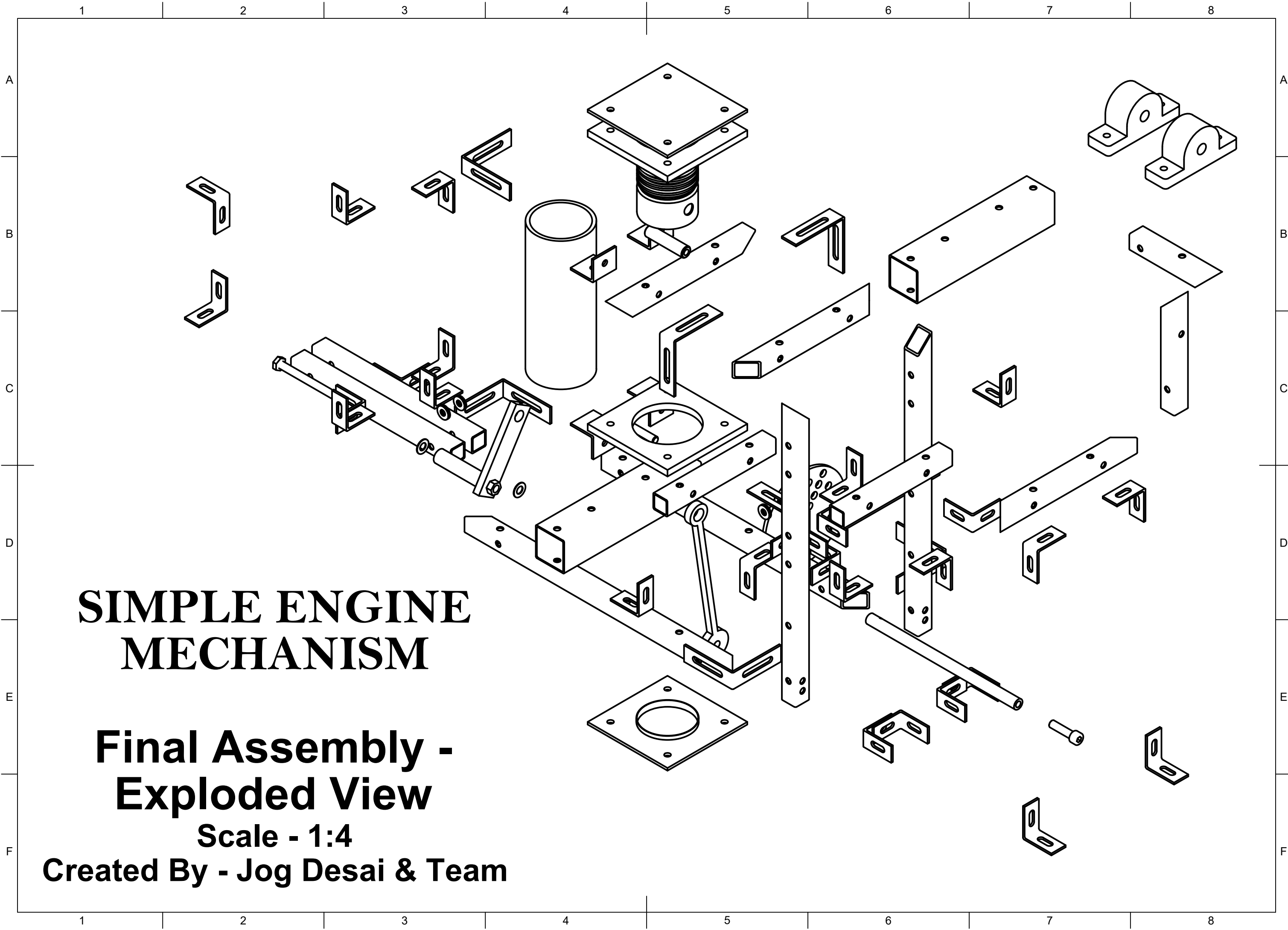

# **SIMPLE ENGINE MECHANISM**

## **Final Assembly - Exploded View**

**Scale - 1:4**

**Created By - Jog Desai & Team**

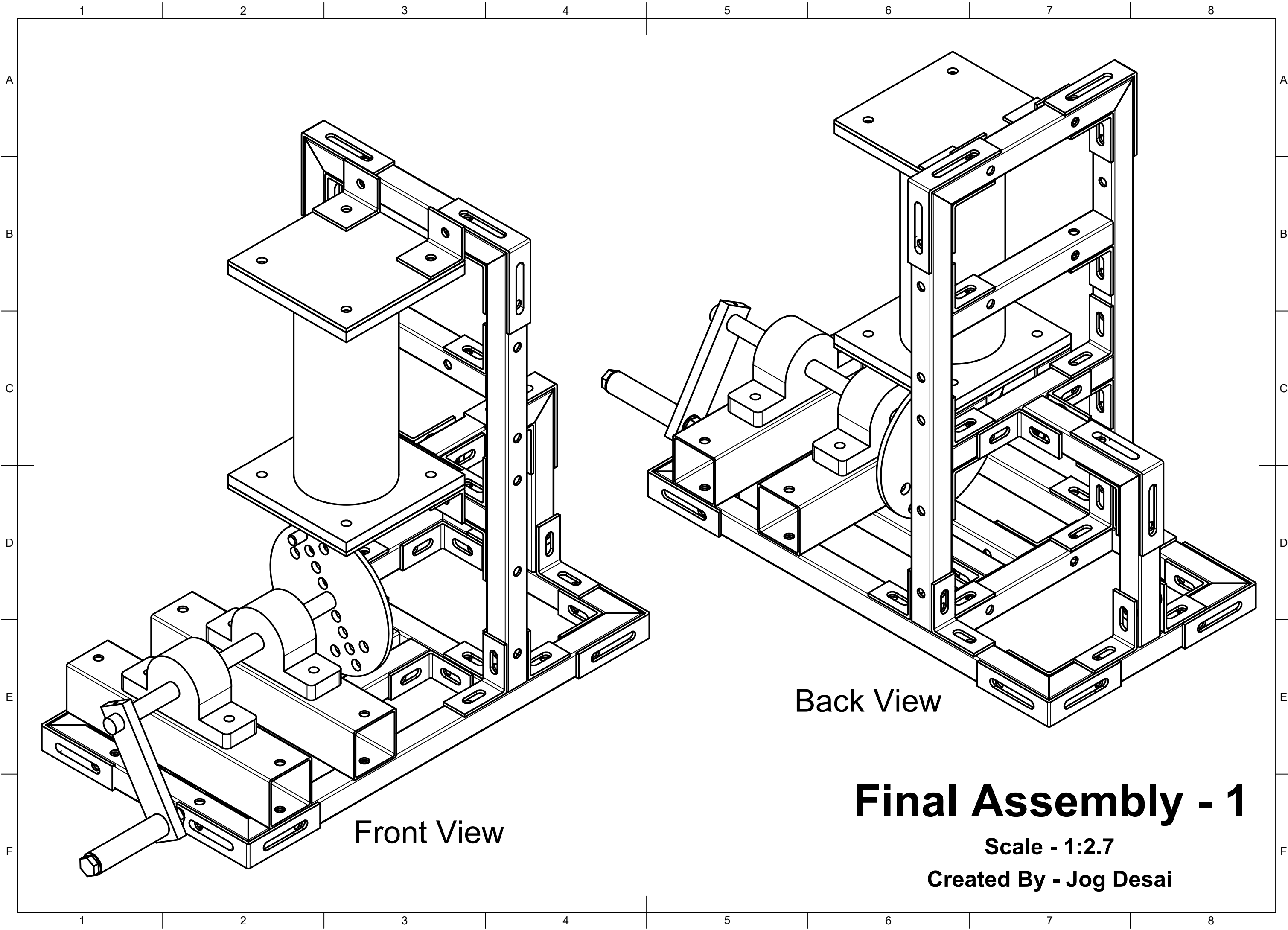

Front View

Back View

# Final Assembly - 1

Scale - 1:2.7

Created By - Jog Desai

1

2

3

4

5

6

7

8

A

B

C

D

E

F

**Assembly Different Isometric Views**  
**Scale - 1:3**  
**Created by - Jog Desai**

A

B

C

D

E

F

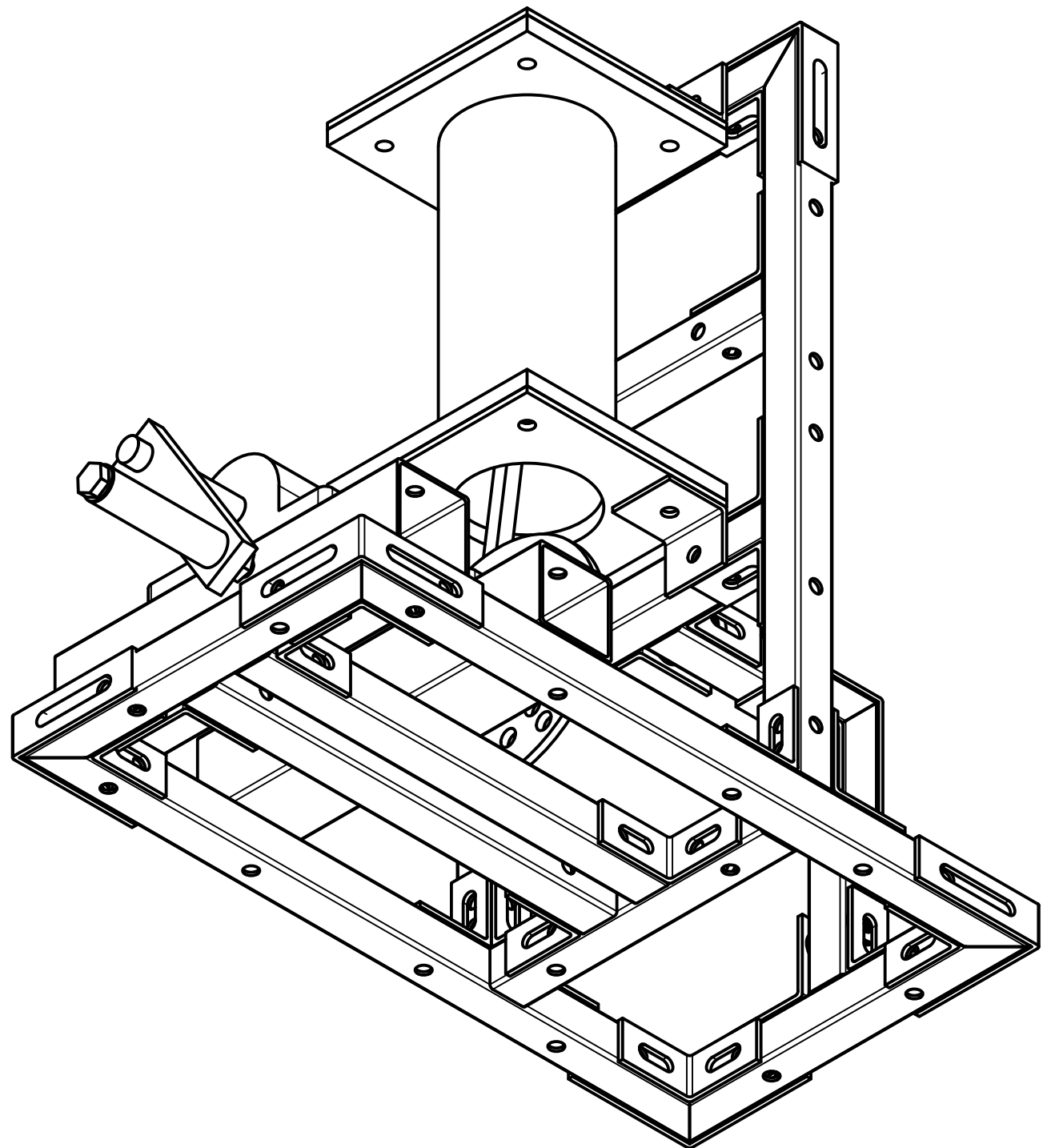
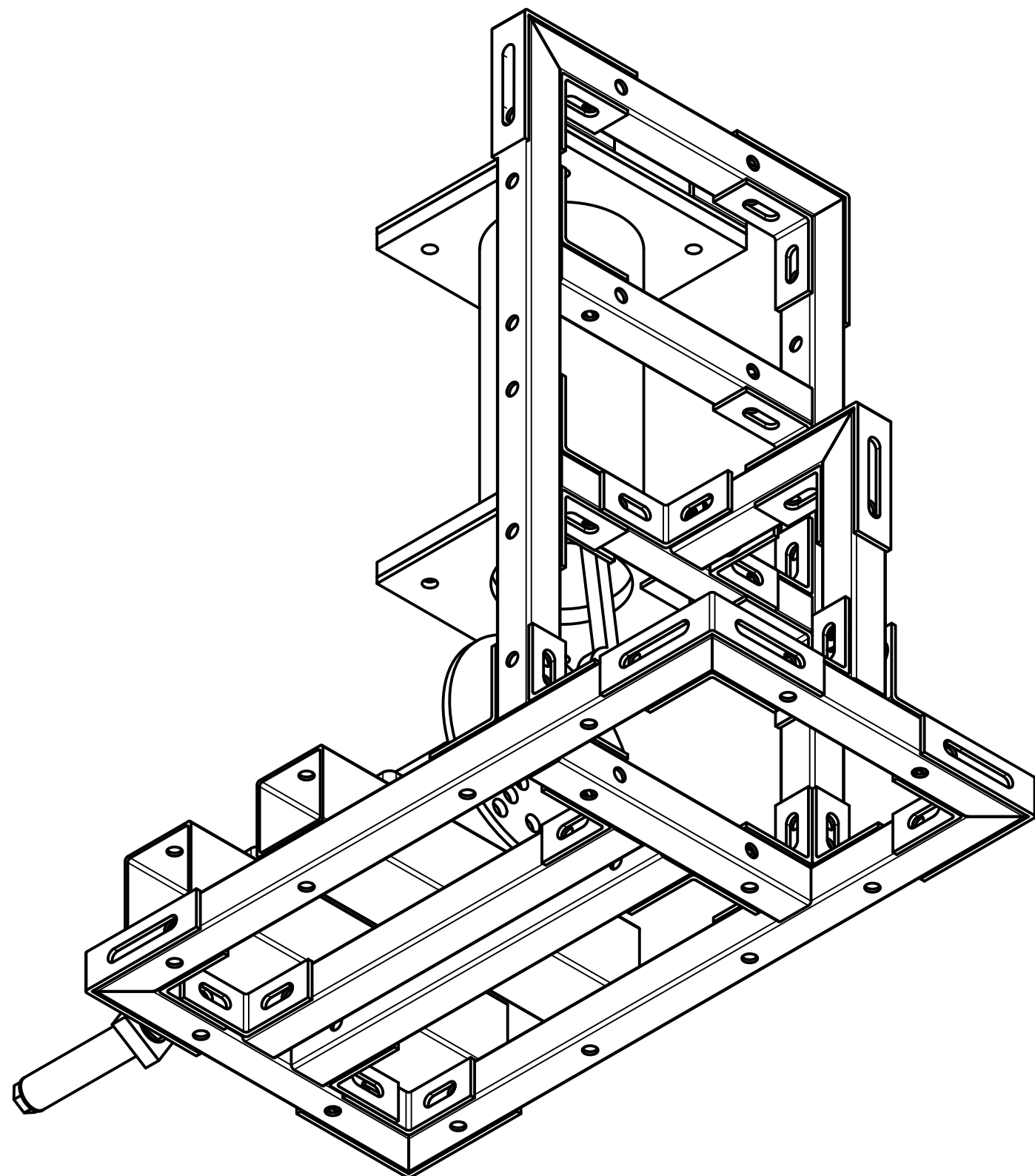

1

2

3

4

5

6

7

8

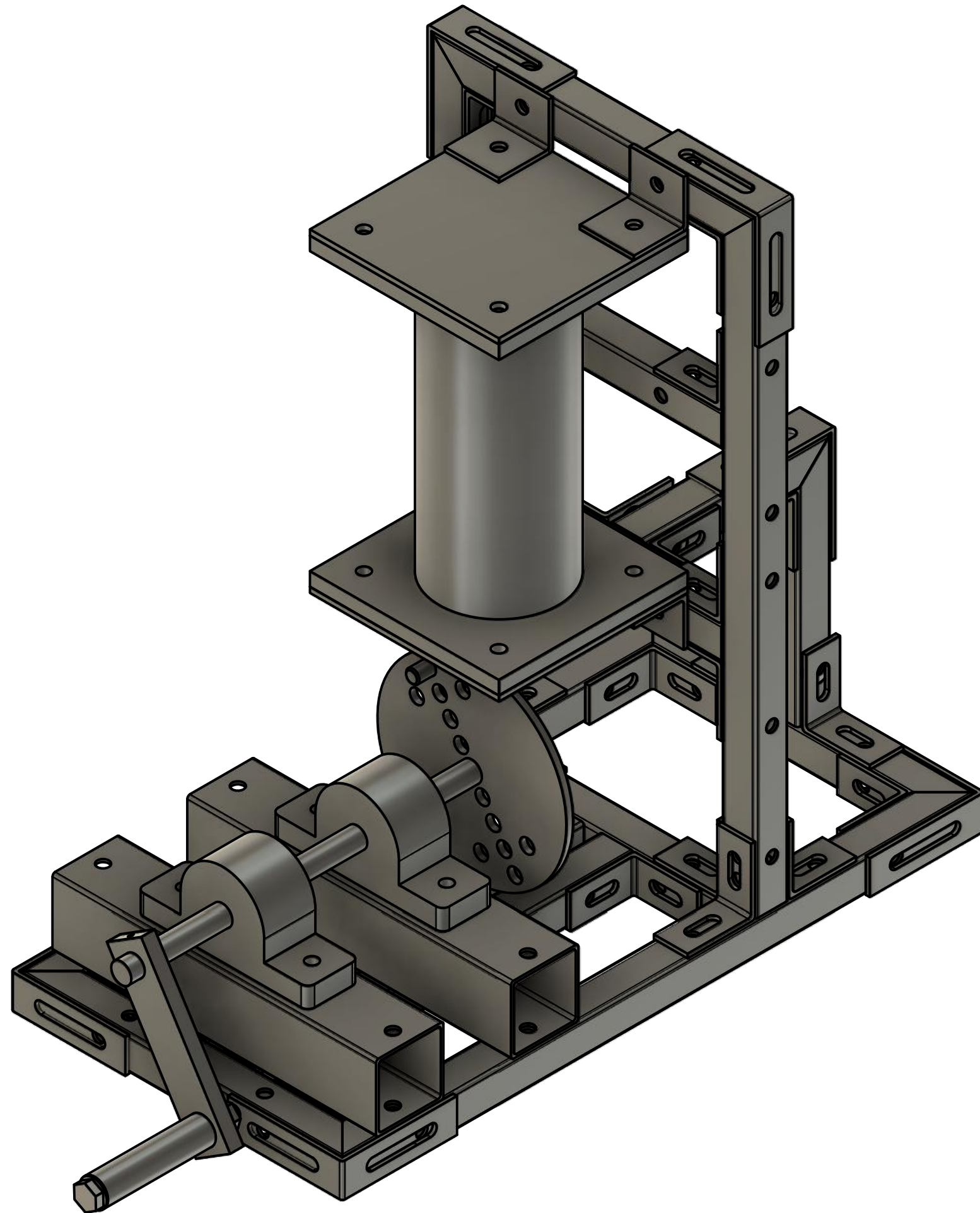

**Final Assembly - 2**  
**Scale - 2:5**  
**Created By - Jog Desai**  
**(Front View)**

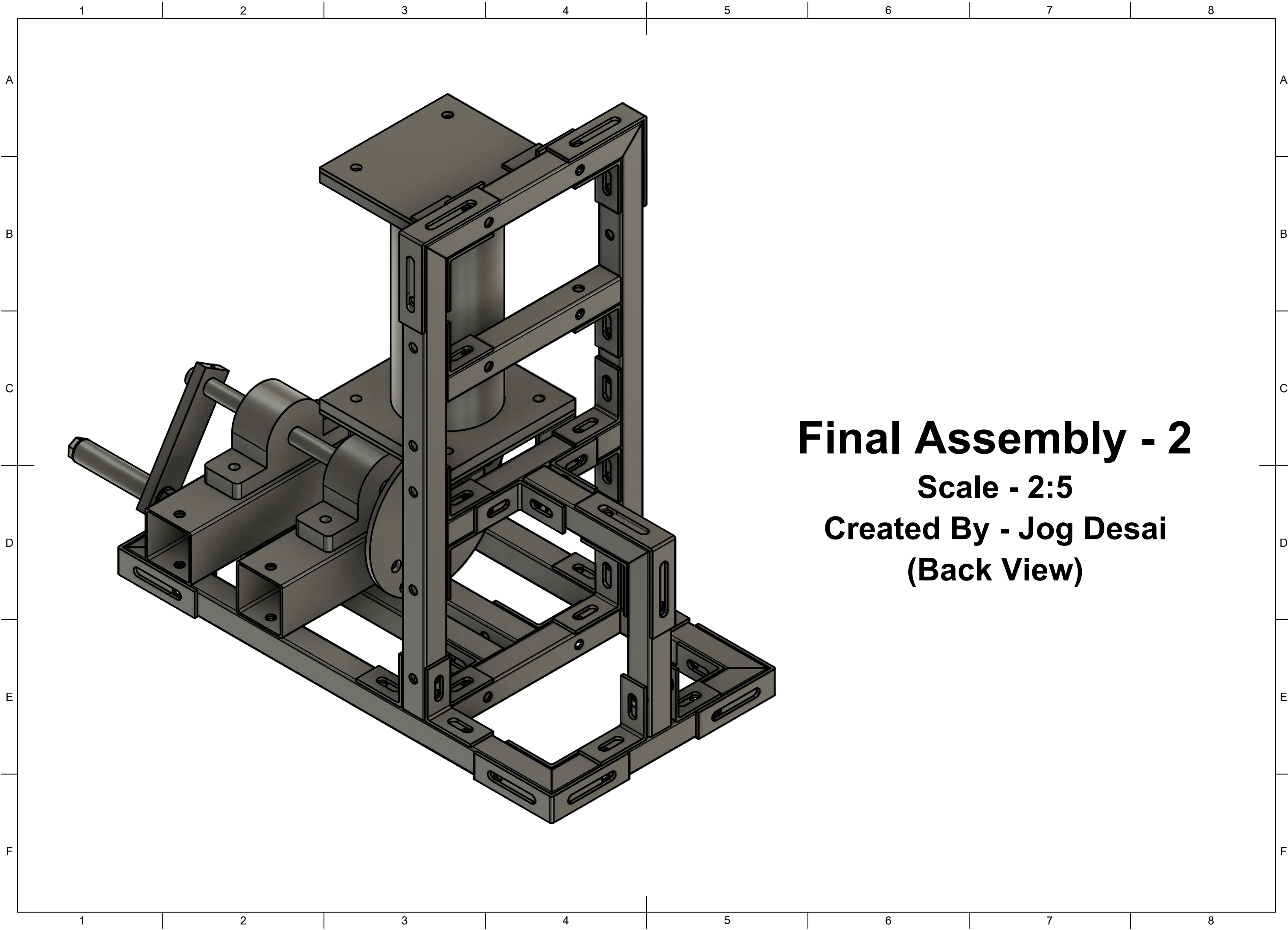

**Final Assembly - 2**  
**Scale - 2:5**  
**Created By - Jog Desai**  
**(Back View)**

1 2 3 4 5 6 7 8

A  
B  
C  
D  
E  
F

**Assembly Different Isometric Views**  
**Scale - 1:3**  
**Created by - Jog Desai**

A  
B  
C  
D  
E  
F

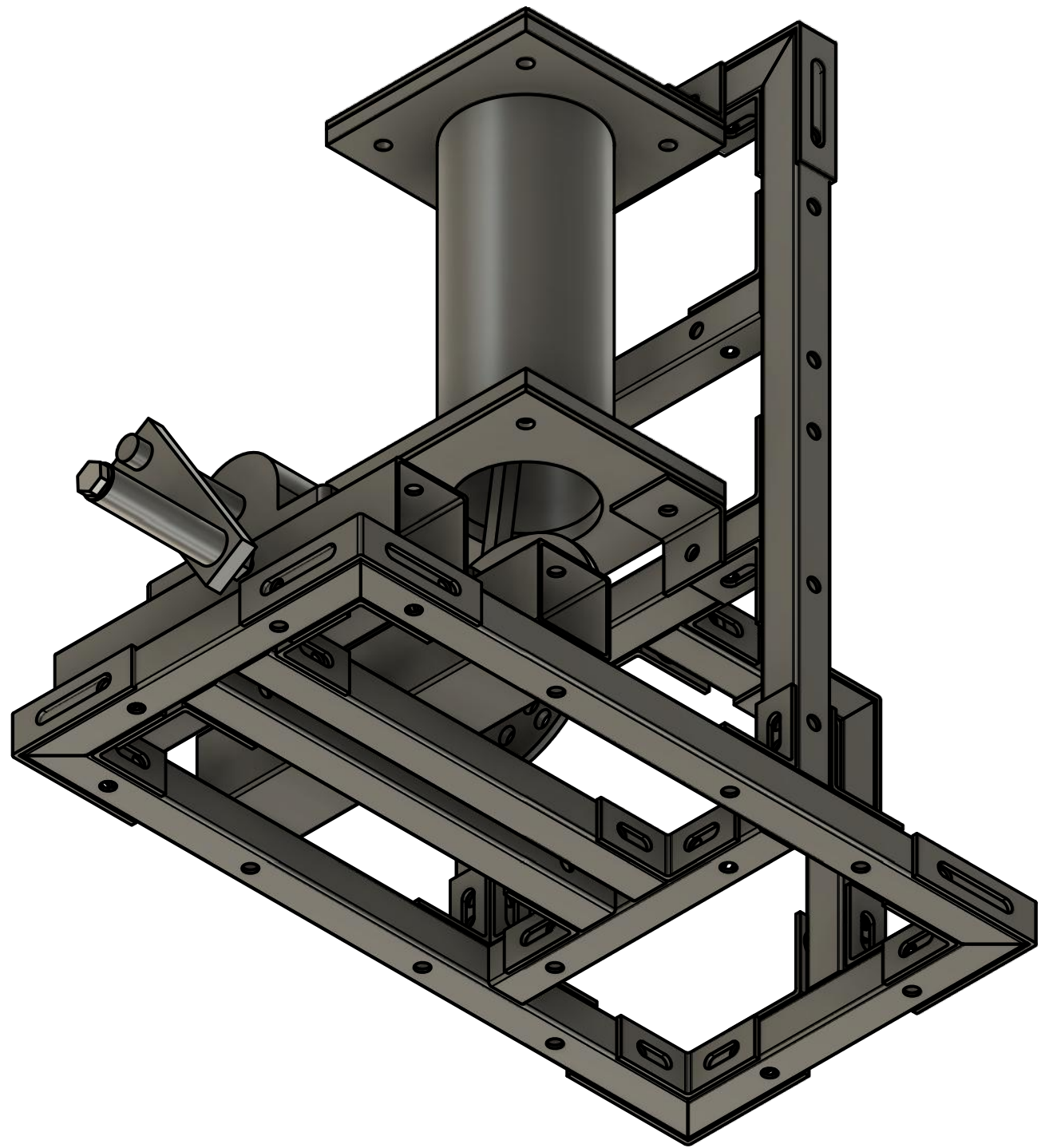
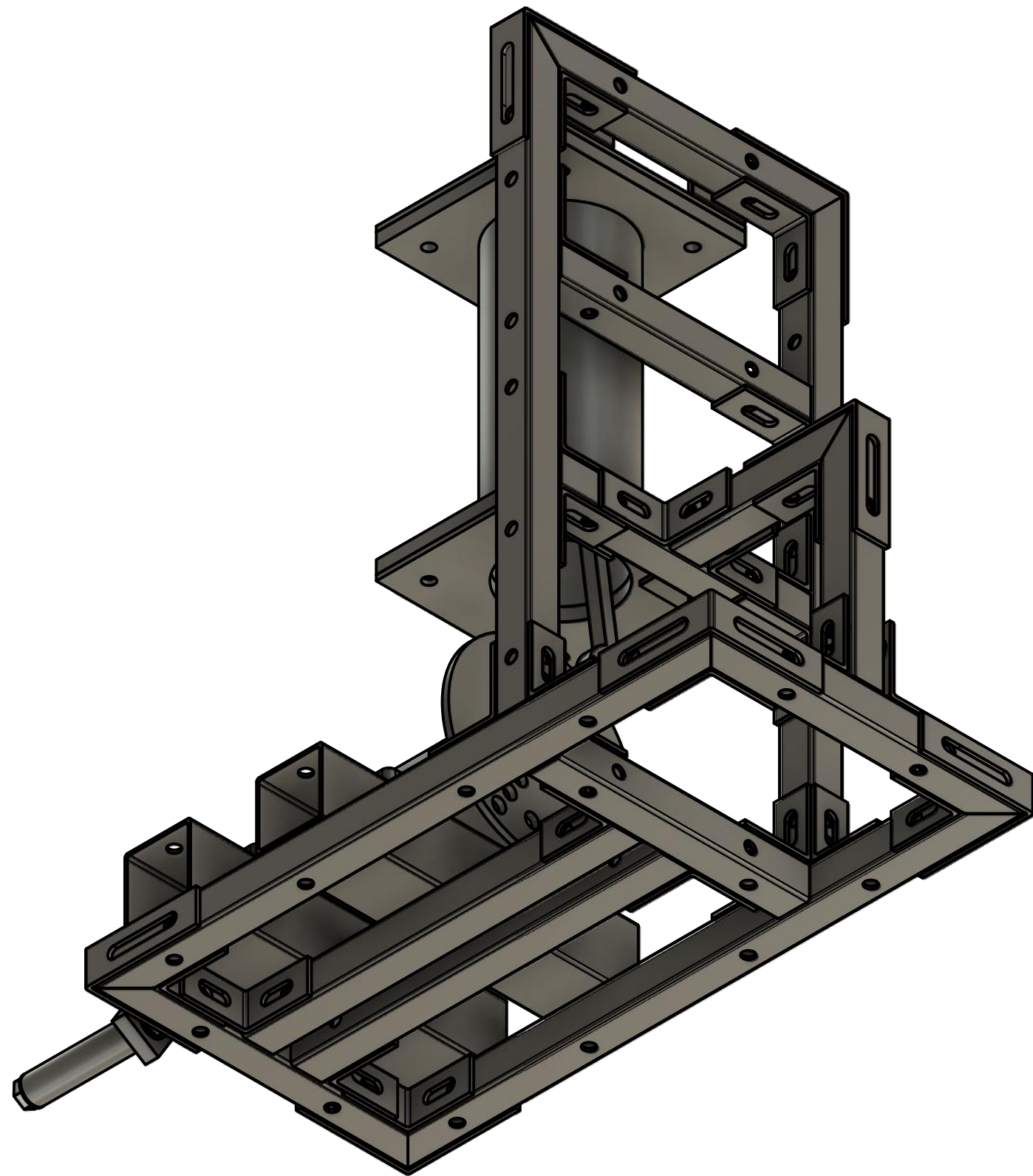

1 2 3 4 5 6 7 8

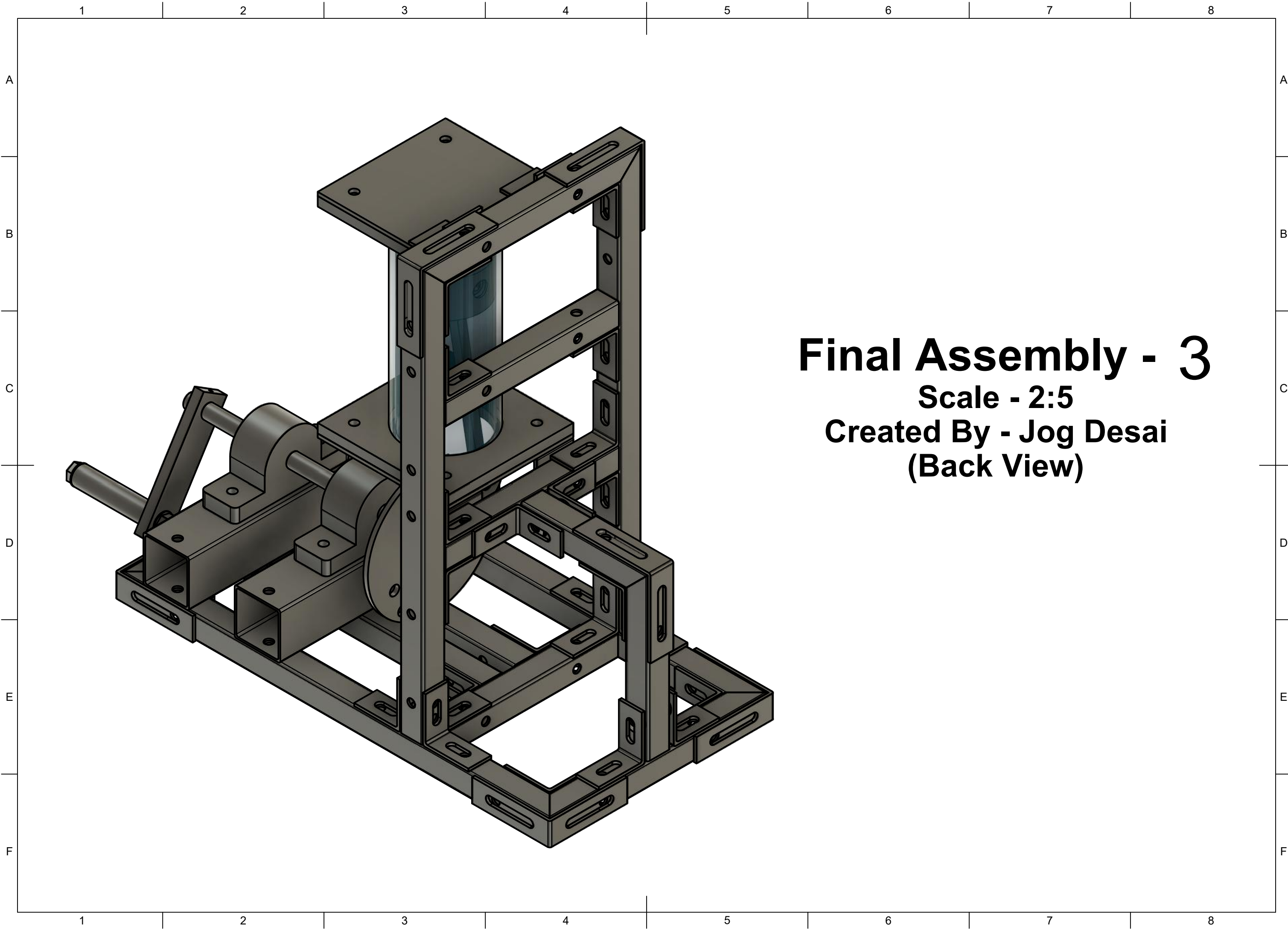

**Final Assembly - 3**  
**Scale - 2:5**  
**Created By - Jog Desai**  
**(Back View)**



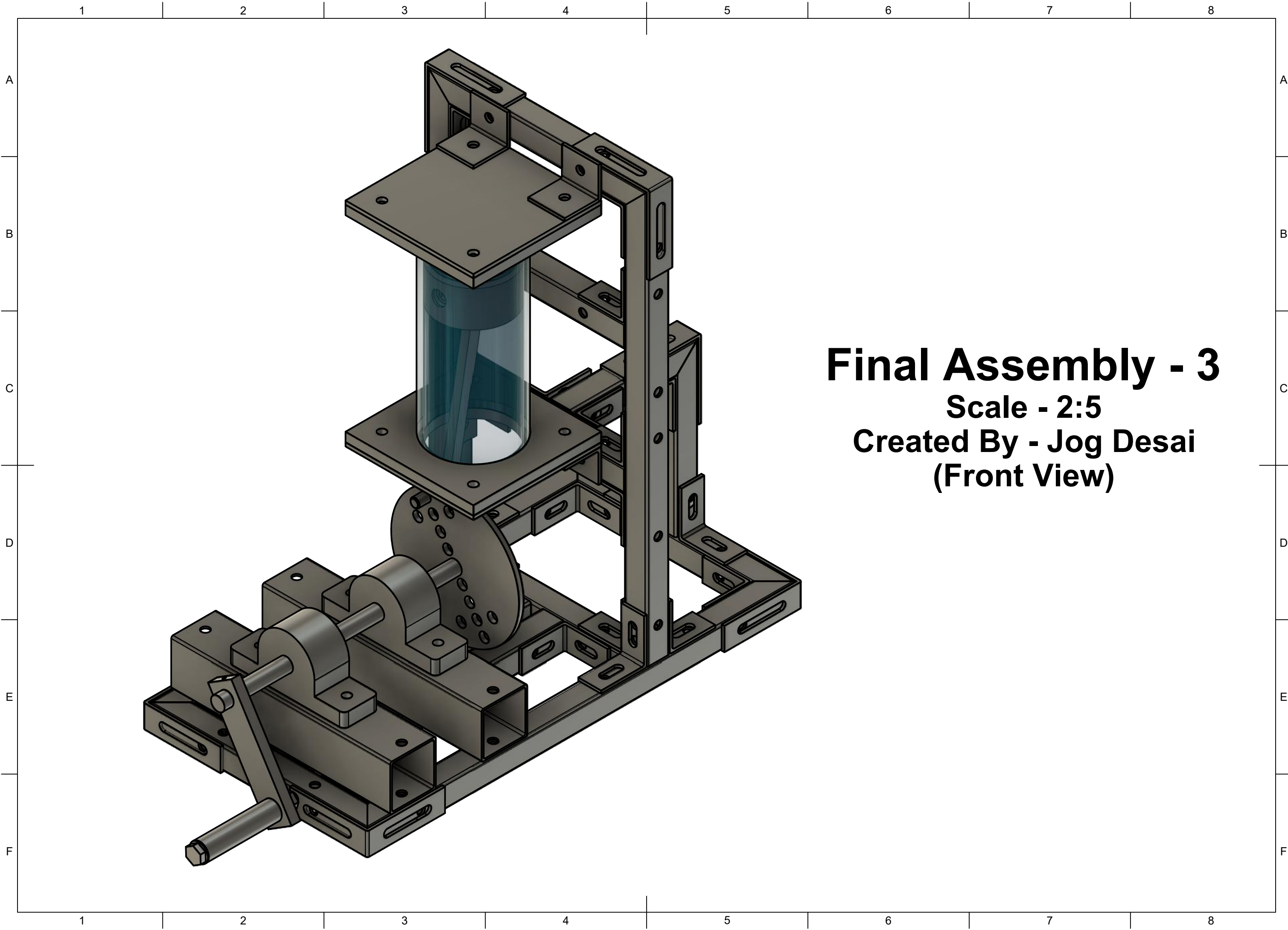

**Final Assembly - 3**  
**Scale - 2:5**  
**Created By - Jog Desai**  
**(Front View)**

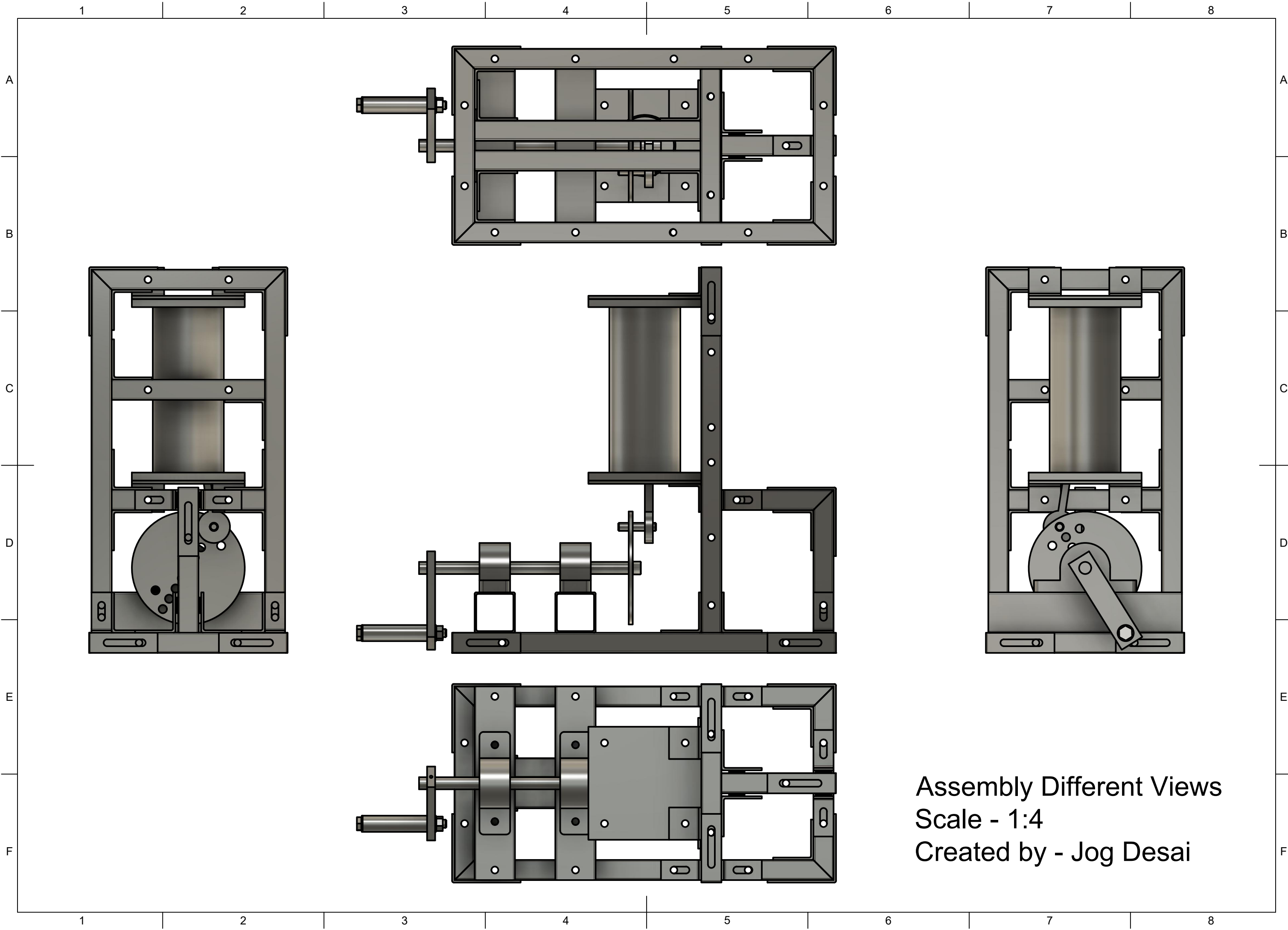

Assembly Different Views  
Scale - 1:4  
Created by - Jog Desai

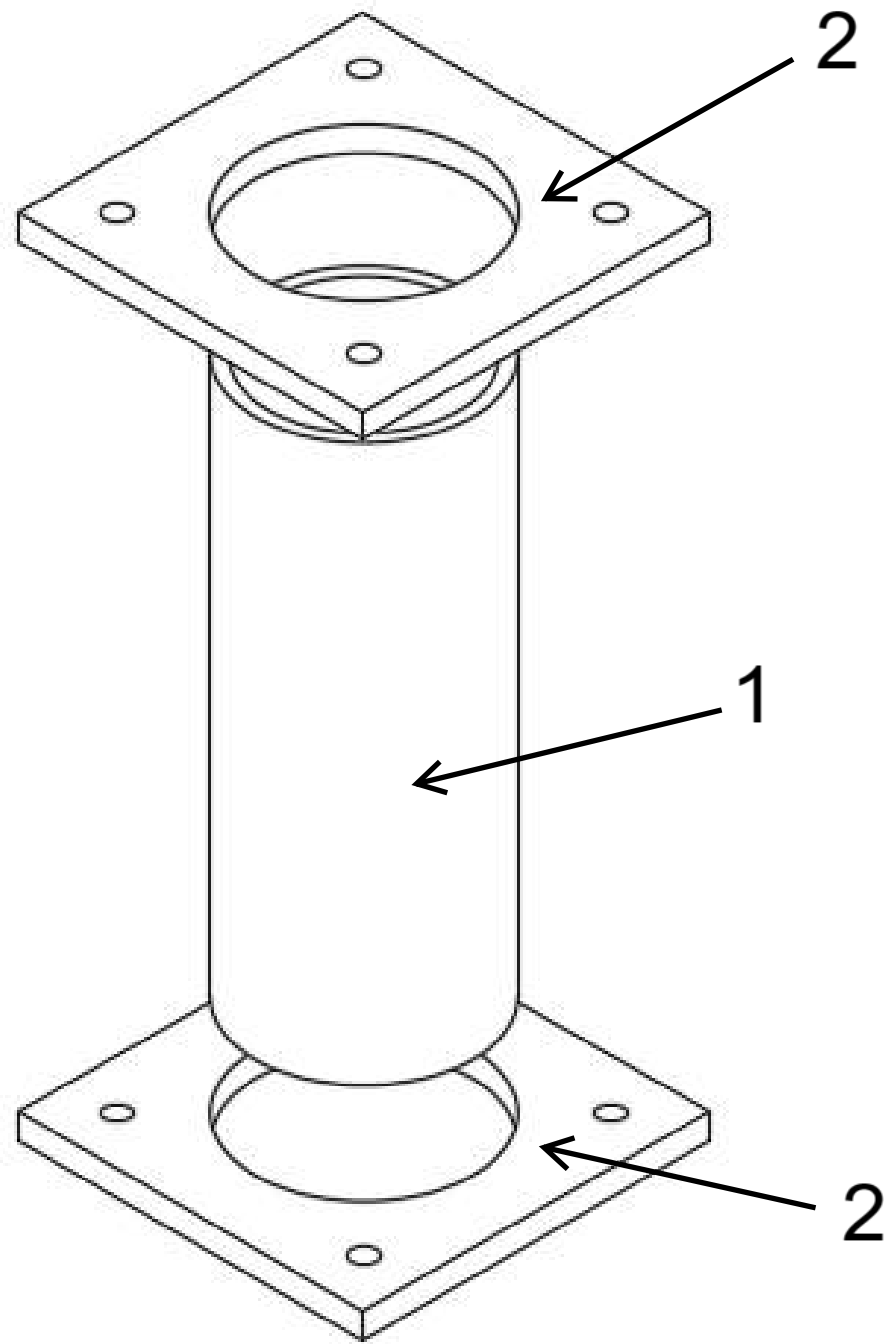

**Exploded View**

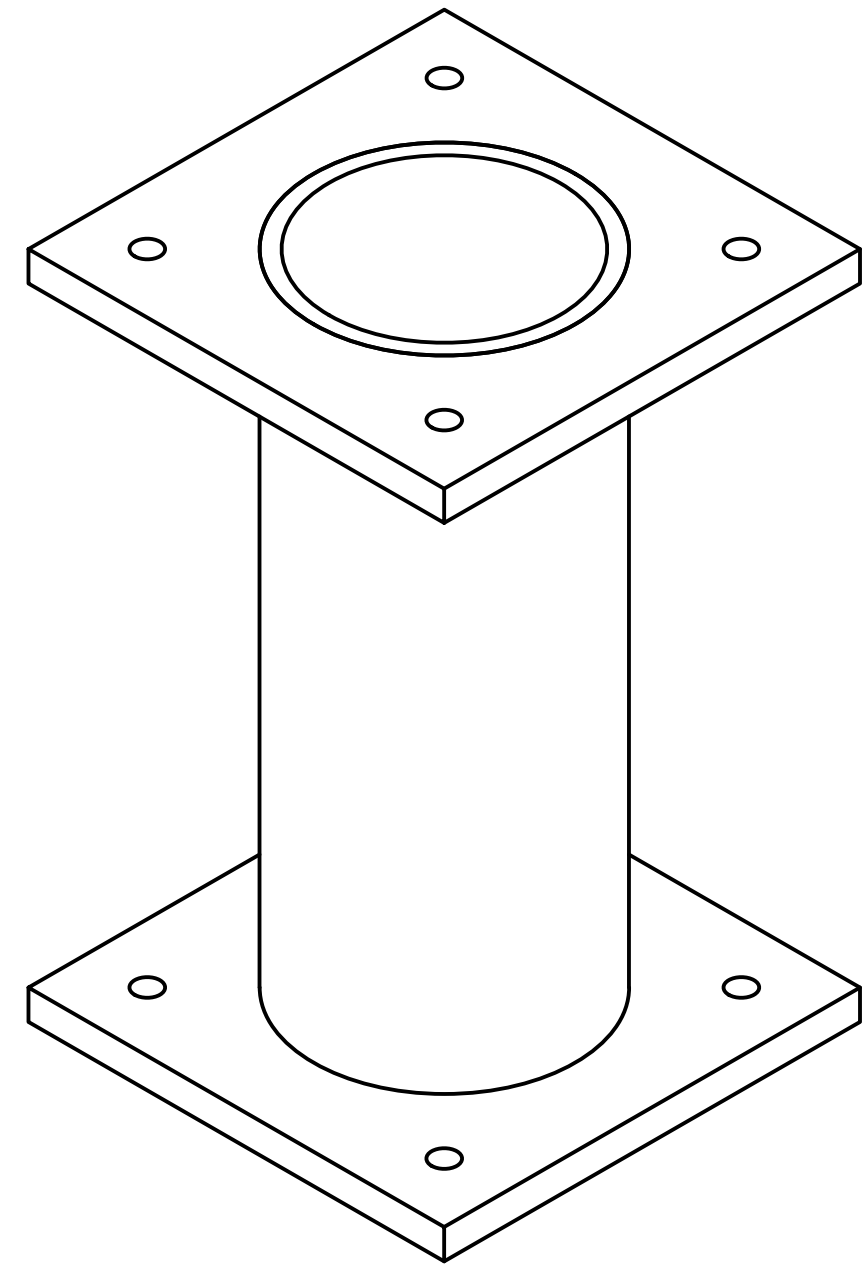

**Cylinder Assembly**

<b>Cylinder Assembly</b>						(Joint Type - Welding)
<b>Sr No.</b>	<b>Part No.</b>	<b>Description</b>	<b>Quantity</b>	<b>Dimensions</b>	<b>Material</b>	
1	SEM01	Cylinder Pipe	1	225 mm x 88 mm x 5.25 mm	Mild Steel	
2	SEM12	Cylinder Plate	2	140 mm x 140 mm x 10 mm	Mild Steel	





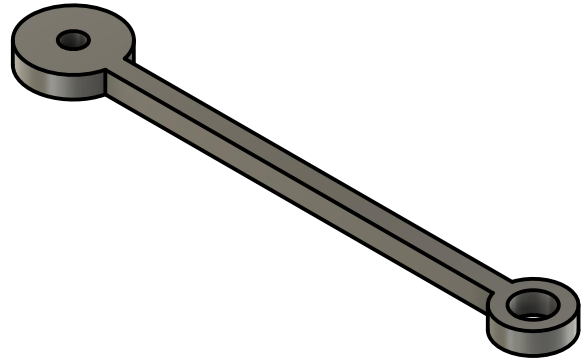
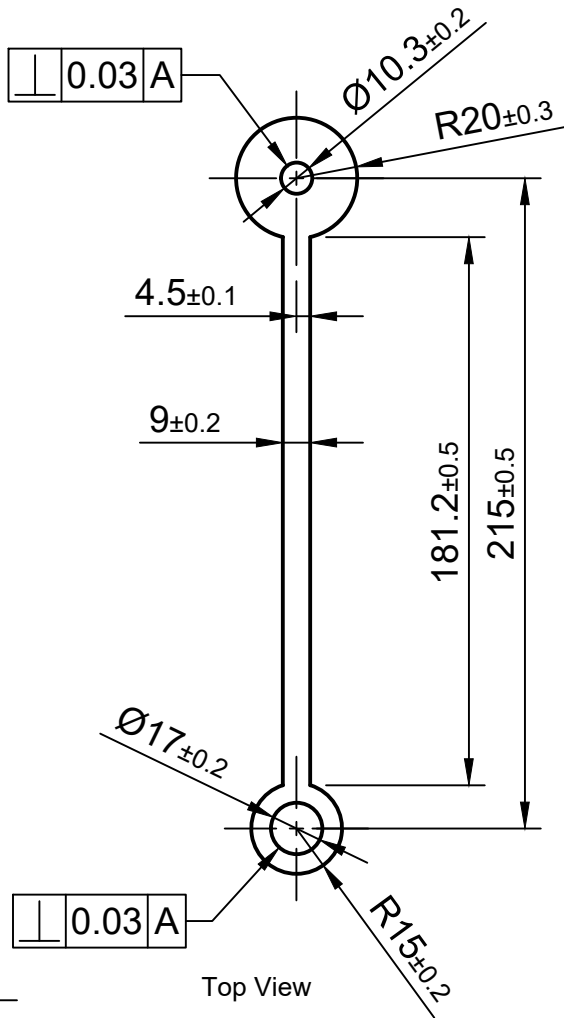

Isometric View

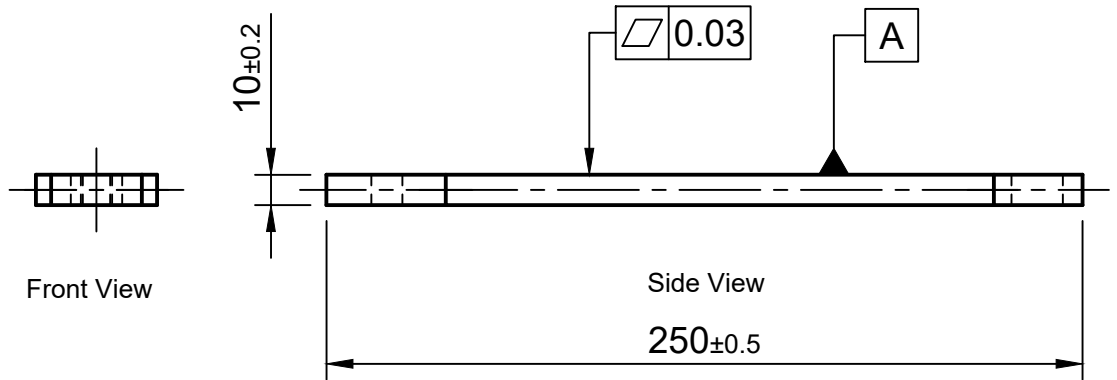

SR. NO.	PART NO	DESCRIPTION	QUANTITY	DIMENSIONS	MATERIAL																																																			
1.	SEM03	Piston Rod	01	250 mm x 40 mm x 10 mm	Mild Steel																																																			
Surface Finish: ✓ Tolerances: Mentioned In The Drawing UNLESS OTHERWISE SPECIFIED DIMENSIONS ARE IN MILLIMETRES		MATERIAL: Mild Steel WEIGHT: 0.260 Kg		DEBURR AND BREAK SHARP EDGES DO NOT SCALE DRAWING																																																				
IF IN DOUBT, ASK		DRN	Name	Date	AHMEDABAD UNIVERSITY SCHOOL OF ENGINEERING AND APPLIED SCIENCE																																																			
Default Tolerance table as per IS:2102		CHD	Jog Desai	03-12-2023																																																				
Welded Construction		Class	Machined and Formed	APD	Jog Desai	03-12-2023																																																		
<table border="1"> <thead> <tr> <th></th> <th>30</th> <th>120</th> <th>315</th> <th>1000</th> <th>2000</th> <th>4000</th> </tr> </thead> <tbody> <tr> <td>+</td> <td>3</td> <td>4</td> <td>6</td> <td>8</td> <td>11</td> <td></td> </tr> <tr> <td>-</td> <td>2</td> <td>2</td> <td>3</td> <td>4</td> <td>6</td> <td></td> </tr> </tbody> </table>			30	120	315	1000	2000	4000	+	3	4	6	8	11		-	2	2	3	4	6		CRS. MED.	<table border="1"> <thead> <tr> <th></th> <th>0.5</th> <th>3</th> <th>6</th> <th>30</th> <th>120</th> <th>400</th> <th>1000</th> <th>2000</th> <th>4000</th> </tr> </thead> <tbody> <tr> <td>+</td> <td>0.2</td> <td>0.3</td> <td>0.5</td> <td>0.8</td> <td>1.2</td> <td>2</td> <td>3</td> <td>4</td> <td></td> </tr> <tr> <td>-</td> <td>0.1</td> <td>0.1</td> <td>0.2</td> <td>0.3</td> <td>0.5</td> <td>0.8</td> <td>1.2</td> <td>2</td> <td></td> </tr> </tbody> </table>		0.5	3	6	30	120	400	1000	2000	4000	+	0.2	0.3	0.5	0.8	1.2	2	3	4		-	0.1	0.1	0.2	0.3	0.5	0.8	1.2	2		Third Angle Projection	
	30	120	315	1000	2000	4000																																																		
+	3	4	6	8	11																																																			
-	2	2	3	4	6																																																			
	0.5	3	6	30	120	400	1000	2000	4000																																															
+	0.2	0.3	0.5	0.8	1.2	2	3	4																																																
-	0.1	0.1	0.2	0.3	0.5	0.8	1.2	2																																																
DSG CH.		DESCRIPTION	DATE	APP.	DRG. NO: 03	No of Pieces: 01																																																		
				SCALE: 2:5	PAPER SIZE: A4	SHEET OF 1 of 1																																																		











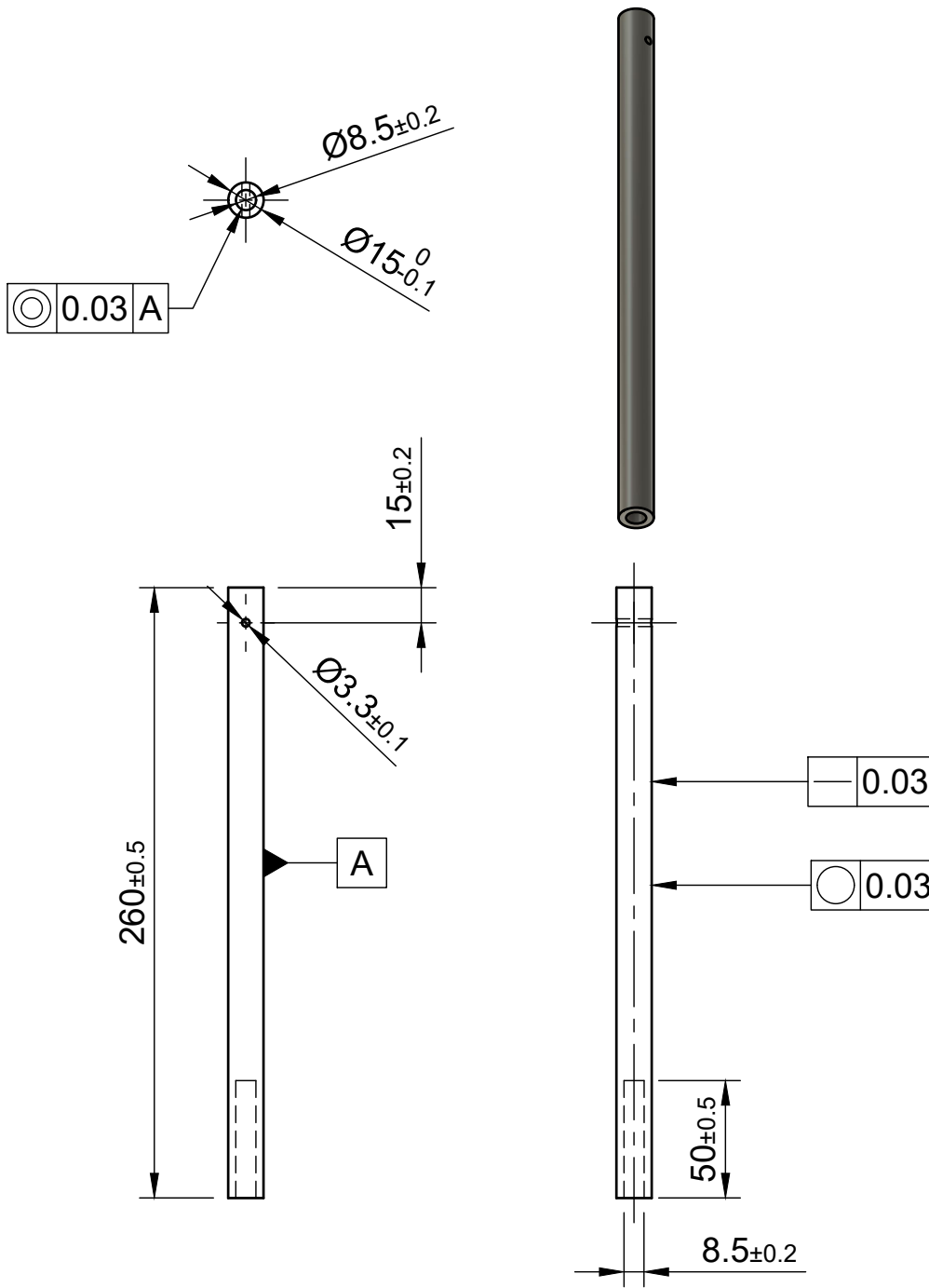

SR. NO.	PART NO	DESCRIPTION	QUANTITY	DIMENSIONS	MATERIAL																																													
1.	SEM08	Shaft	01	260 mm x 15 mm	Mild Steel																																													
Surface Finish: <input checked="" type="checkbox"/> Tolerances: Mentioned In The Drawing UNLESS OTHERWISE SPECIFIED DIMENSIONS ARE IN MILLIMETRES		MATERIAL: Mild Steel WEIGHT: 0.360 Kg		DEBURR AND BREAK SHARP EDGES DO NOT SCALE DRAWING																																														
IF IN DOUBT, ASK		DRN	Jog Desai	03-12-2023	MEC405 LEARNING FACTORY PROJECT																																													
Default Tolerance table as per IS:2102		CHD	Jog Desai	03-12-2023																																														
Welded Construction		APD	Jog Desai	03-12-2023																																														
Class		Machined and Formed		TITLE: Shaft	Part No: SEM08																																													
<table border="1"> <thead> <tr> <th></th> <th>30</th> <th>120</th> <th>315</th> <th>1000</th> <th>2000</th> </tr> </thead> <tbody> <tr> <td>+</td> <td>3</td> <td>4</td> <td>6</td> <td>8</td> <td>11</td> </tr> <tr> <td>-</td> <td>2</td> <td>2</td> <td>3</td> <td>4</td> <td>6</td> </tr> </tbody> </table>			30	120	315	1000	2000	+	3	4	6	8	11	-	2	2	3	4	6	<table border="1"> <thead> <tr> <th></th> <th>0.5</th> <th>3</th> <th>6</th> <th>30</th> <th>120</th> <th>400</th> <th>1000</th> <th>2000</th> </tr> </thead> <tbody> <tr> <td>+</td> <td>0.2</td> <td>0.3</td> <td>0.5</td> <td>0.8</td> <td>1.2</td> <td>2</td> <td>3</td> <td>4</td> </tr> <tr> <td>-</td> <td>0.1</td> <td>0.1</td> <td>0.2</td> <td>0.3</td> <td>0.5</td> <td>0.8</td> <td>1.2</td> <td>2</td> </tr> </tbody> </table>			0.5	3	6	30	120	400	1000	2000	+	0.2	0.3	0.5	0.8	1.2	2	3	4	-	0.1	0.1	0.2	0.3	0.5	0.8	1.2	2	DRG. NO: 08 No of Pieces: 01	
	30	120	315	1000	2000																																													
+	3	4	6	8	11																																													
-	2	2	3	4	6																																													
	0.5	3	6	30	120	400	1000	2000																																										
+	0.2	0.3	0.5	0.8	1.2	2	3	4																																										
-	0.1	0.1	0.2	0.3	0.5	0.8	1.2	2																																										
DSG CH.		DESCRIPTION	DATE	APP.	SCALE: 1:3																																													
					PAPER SIZE: A4																																													
					SHEET OF 1 of 1																																													



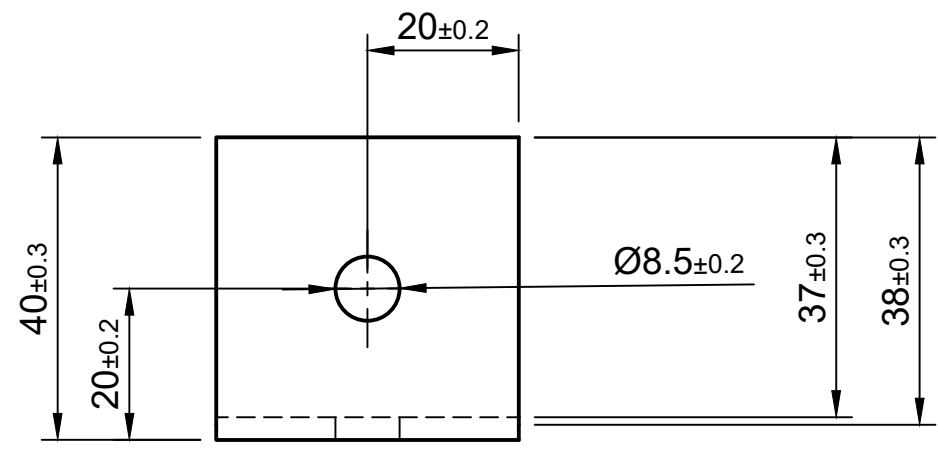

Top View

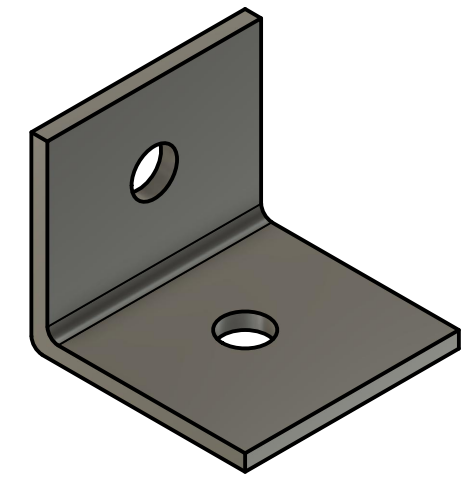

Isometric View

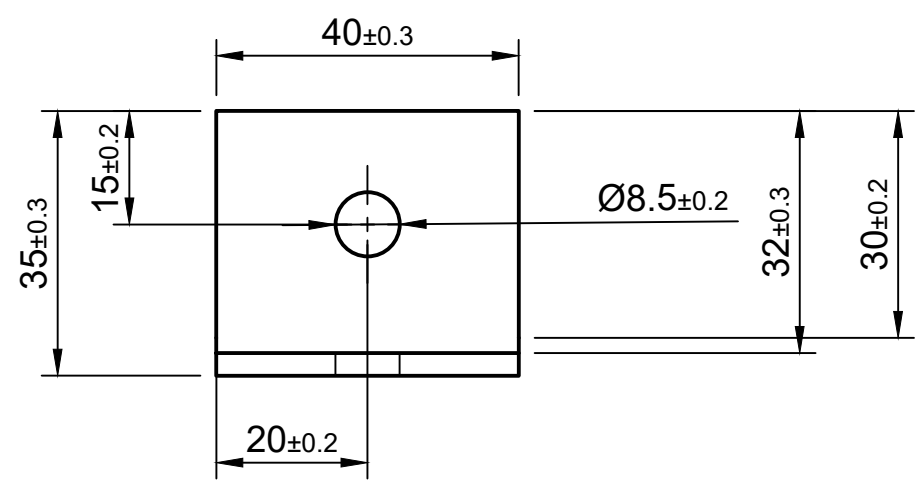

Front View

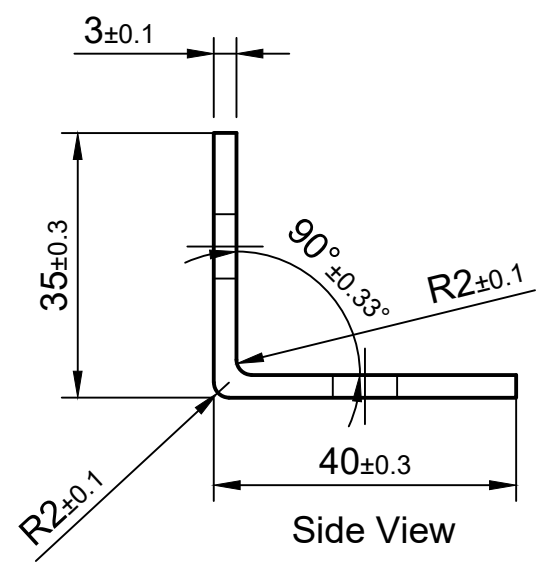

Side View

SR. NO.	PART NO	DESCRIPTION	QUANTITY	DIMENSIONS	MATERIAL
1.	<b>SEM10</b>	<b>Clamp - 3 - Small</b>	<b>04</b>	<b>35 mm x 40 mm x 3 mm</b>	<b>Mild Steel</b>

Surface Finish: ✓ Tolerances: Mentioned In The Drawing UNLESS OTHERWISE SPECIFIED DIMENSIONS ARE IN MILLIMETRES	MATERIAL: Mild Steel		DEBURR AND BREAK SHARP EDGES		<b>AHMEDABAD UNIVERSITY</b>
	WEIGHT: 0.065 Kg		DO NOT SCALE DRAWING		

IF IN DOUBT, ASK	DRN	Jog Desai	03-12-2023	<b>MEC405 LEARNING FACTORY PROJECT</b>	
------------------	-----	-----------	------------	--	--

Default Tolerance table as per IS:2102				CHD	Jog Desai	03-12-2023	TITLE:	Part No:
--	--	--	--	-----	-----------	------------	--------	----------

Welded Construction		Class	Machined and Formed				APD	Jog Desai	03-12-2023	<b>Clamp - 3 - Small</b>	<b>SEM10</b>
---------------------	--	-------	---------------------	--	--	--	-----	-----------	------------	--------------------------	--------------

	30 120	120 315	315 1000	1000 2000	2000 4000		0.5 3	3 6	6 30	30 120	120 400	400 1000	1000 2000	2000 4000	Third Angle Projection	DRG. NO:	No of Pieces:
+	3	4	6	8	11	<b>CRS.</b>	0.2	0.3	0.5	0.8	1.2	2	3	4		<b>10</b>	<b>04</b>
-	2	2	3	4	6	<b>MED.</b>	0.1	0.1	0.2	0.3	0.5	0.8	1.2	2			

DSG CH.	DESCRIPTION	DATE	APP.	SCALE: <b>1:1</b>	PAPER SIZE: A3	SHEET OF 1 of 1
---------	-------------	------	------	-------------------	----------------	-----------------





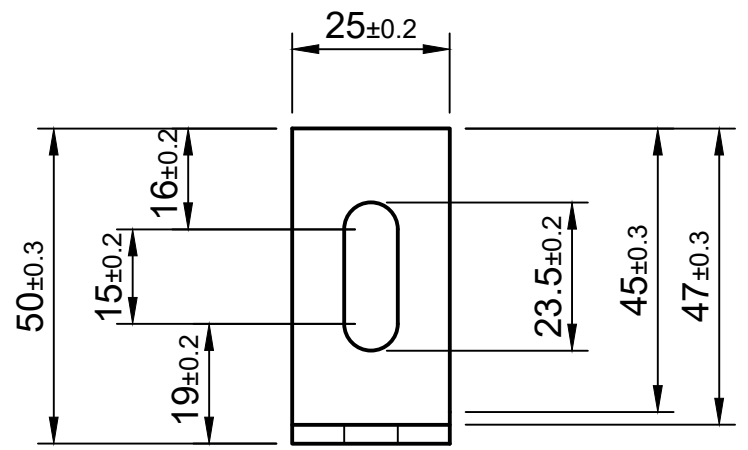

Top View

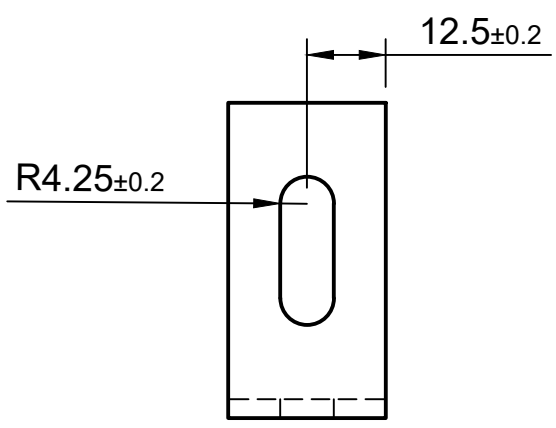

Front View

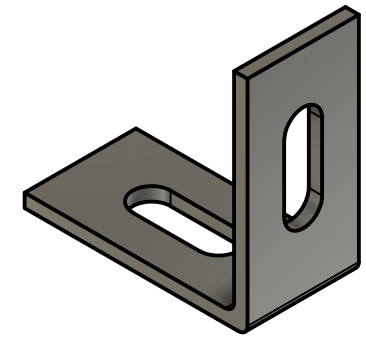

Isometric View

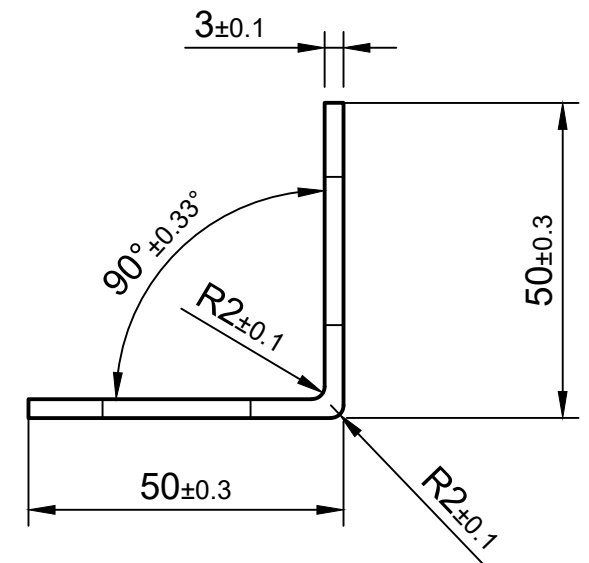

Side View

SR. NO.	PART NO	DESCRIPTION	QUANTITY	DIMENSIONS	MATERIAL
1.	<b>SEM13</b>	<b>Clamp - 1 - Medium</b>	<b>25</b>	<b>50 mm x 25 mm x 3 mm</b>	<b>Mild Steel</b>

Surface Finish: ✓ Tolerances: Mentioned In The Drawing UNLESS OTHERWISE SPECIFIED DIMENSIONS ARE IN MILLIMETRES	MATERIAL: Mild Steel		DEBURR AND BREAK SHARP EDGES		<b>AHMEDABAD UNIVERSITY</b> SCHOOL OF ENGINEERING AND APPLIED SCIENCE	
	WEIGHT: 0.050 Kg		DO NOT SCALE DRAWING			

IF IN DOUBT, ASK	DRN	Jog Desai	03-12-2023	<b>MEC405 LEARNING FACTORY PROJECT</b>		
------------------	-----	-----------	------------	--	--	--

Default Tolerance table as per IS:2102				CHD	Jog Desai	03-12-2023	TITLE:	Part No:
--	--	--	--	-----	-----------	------------	--------	----------

Welded Construction		Class	Machined and Formed				APD	Jog Desai	03-12-2023	<b>Clamp - 1 - Medium</b>	<b>SEM13</b>
---------------------	--	-------	---------------------	--	--	--	-----	-----------	------------	---------------------------	--------------

	30 120	120 315	315 1000	1000 2000	2000 4000		0.5 3	3 6	6 30	30 120	120 400	400 1000	1000 2000	2000 4000	Third Angle Projection	DRG. NO:	No of Pieces:
+	3	4	6	8	11	<b>CRS.</b>	0.2	0.3	0.5	0.8	1.2	2	3	4		<b>13</b>	<b>25</b>
-	2	2	3	4	6	<b>MED.</b>	0.1	0.1	0.2	0.3	0.5	0.8	1.2	2			

DSG CH.	DESCRIPTION	DATE	APP.	SCALE: <b>1:1.2</b>	PAPER SIZE: A3	SHEET OF 1 of 1
---------	-------------	------	------	---------------------	----------------	-----------------









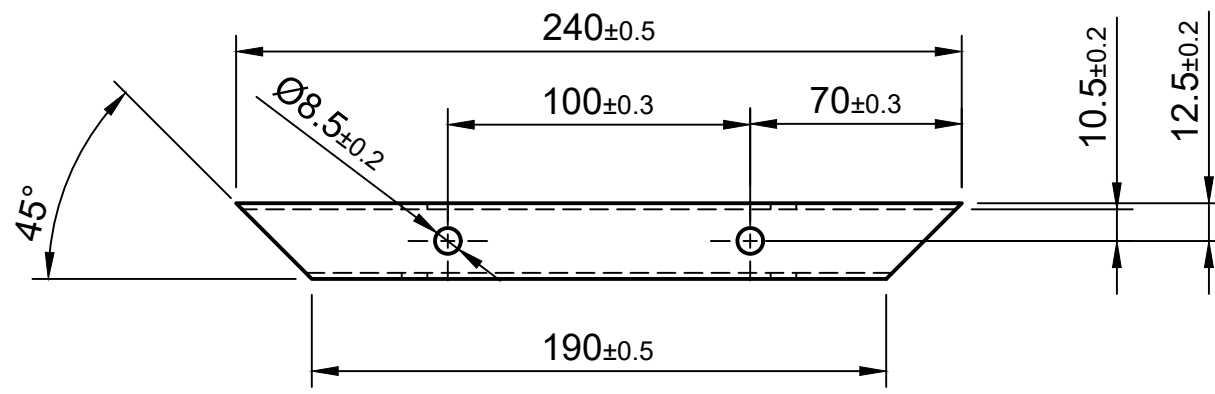

Top View

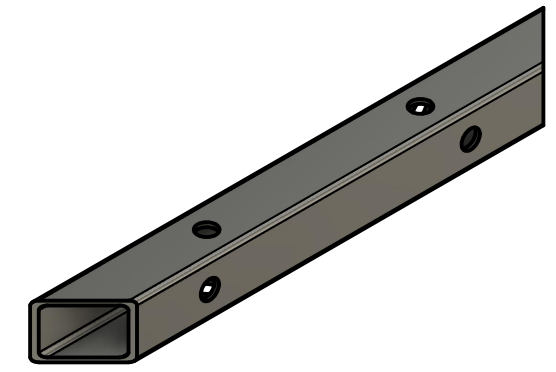

Isometric View

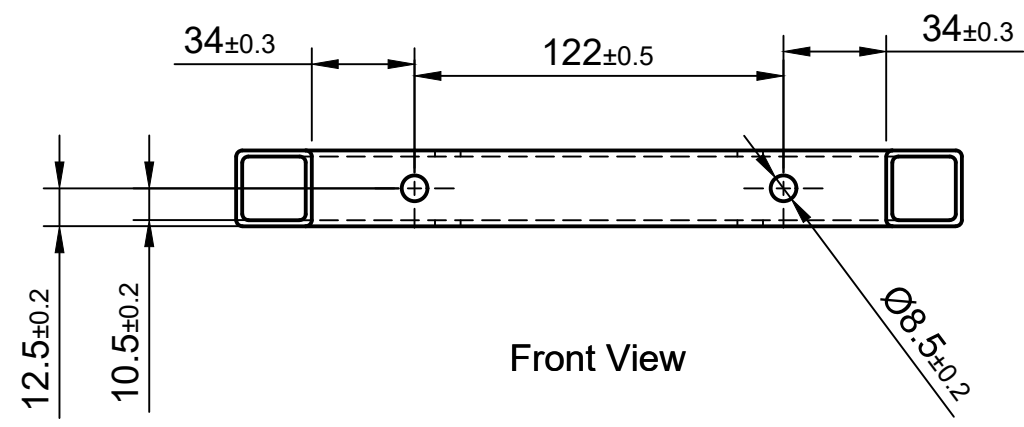

Front View

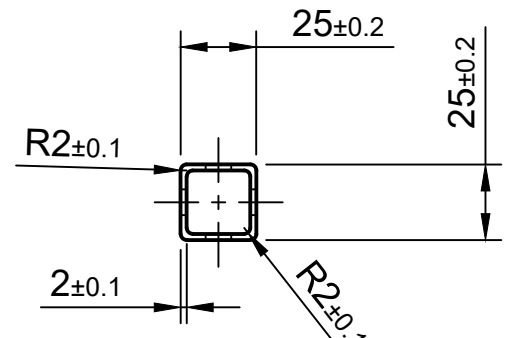

Side View

SR. NO.	PART NO	DESCRIPTION	QUANTITY	DIMENSIONS	MATERIAL
1.	<b>SEM17</b>	<b>Bar - 240</b>	<b>03</b>	<b>240 mm x 25 mm x 25 mm x 2 mm</b>	<b>Mild Steel</b>

Surface Finish: ✓ Tolerances: Mentioned In The Drawing UNLESS OTHERWISE SPECIFIED DIMENSIONS ARE IN MILLIMETRES	MATERIAL: Mild Steel		DEBURR AND BREAK SHARP EDGES		<b>AHMEDABAD UNIVERSITY</b>
	WEIGHT: 0.190 Kg		DO NOT SCALE DRAWING		

IF IN DOUBT, ASK	DRN	Jog Desai	03-12-2023	<b>MEC405 LEARNING FACTORY PROJECT</b>	
------------------	-----	-----------	------------	--	--

Default Tolerance table as per IS:2102				CHD	Jog Desai	03-12-2023	TITLE:	Part No:
--	--	--	--	-----	-----------	------------	--------	----------

Welded Construction		Class	Machined and Formed				APD	Jog Desai	03-12-2023	<b>Bar - 240</b>	<b>SEM17</b>
---------------------	--	-------	---------------------	--	--	--	-----	-----------	------------	------------------	--------------

	30 120	120 315	315 1000	1000 2000	2000 4000		0.5 3	3 6	6 30	30 120	120 400	400 1000	1000 2000	2000 4000	Third Angle Projection	DRG. NO:	No of Pieces:
+	3	4	6	8	11	<b>CRS.</b>	0.2	0.3	0.5	0.8	1.2	2	3	4		<b>17</b>	<b>03</b>
-	2	2	3	4	6	<b>MED.</b>	0.1	0.1	0.2	0.3	0.5	0.8	1.2	2			

DSG CH.	DESCRIPTION	DATE	APP.	SCALE: <b>2:5</b>	PAPER SIZE: A3	SHEET OF 1 of 1
---------	-------------	------	------	-------------------	----------------	-----------------

1	2	3	4	5	6	7	8
---	---	---	---	---	---	---	---

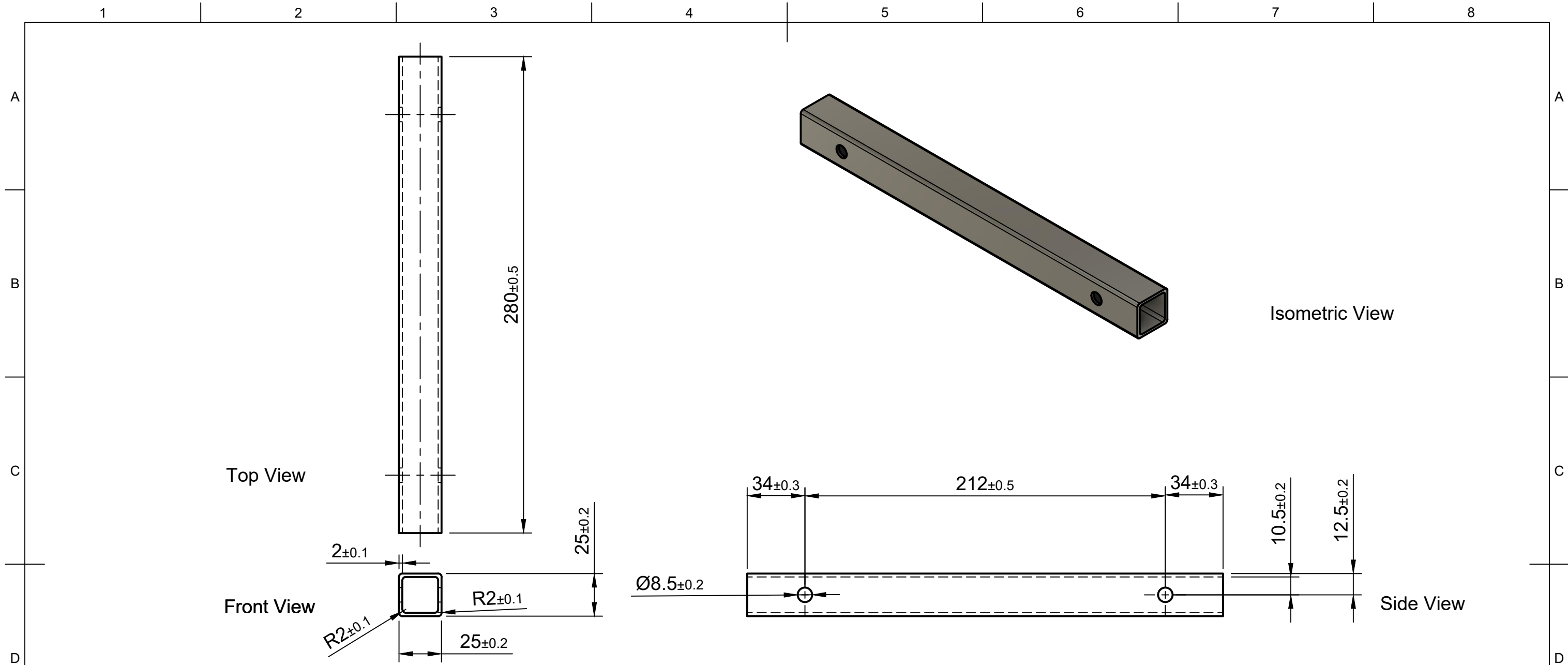

SR. NO.	PART NO	DESCRIPTION	QUANTITY	DIMENSIONS	MATERIAL																																										
1.	<b>SEM18</b>	<b>Bar - 280</b>	<b>02</b>	<b>280 mm x 25 mm x 25 mm x 2 mm</b>	<b>Mild Steel</b>																																										
Surface Finish: ✓ Tolerances: Mentioned In The Drawing UNLESS OTHERWISE SPECIFIED DIMENSIONS ARE IN MILLIMETRES		MATERIAL: Mild Steel WEIGHT: 0.235 Kg		DEBURR AND BREAK SHARP EDGES DO NOT SCALE DRAWING																																											
IF IN DOUBT, ASK		Default Tolerance table as per IS:2102		AHMEDABAD UNIVERSITY SCHOOL OF ENGINEERING AND APPLIED SCIENCE																																											
Welded Construction		Class		Machined and Formed																																											
<table border="1"> <tr> <td></td> <td>30 120</td> <td>120 315</td> <td>315 1000</td> <td>1000 2000</td> <td>2000 4000</td> </tr> <tr> <td>+</td> <td>3</td> <td>4</td> <td>6</td> <td>8</td> <td>11</td> </tr> <tr> <td>-</td> <td>2</td> <td>2</td> <td>3</td> <td>4</td> <td>6</td> </tr> </table>			30 120	120 315	315 1000	1000 2000	2000 4000	+	3	4	6	8	11	-	2	2	3	4	6	<table border="1"> <tr> <td>0.5 3</td> <td>3 6</td> <td>6 30</td> <td>30 120</td> <td>120 400</td> <td>400 1000</td> <td>1000 2000</td> <td>2000 4000</td> </tr> <tr> <td>0.2</td> <td>0.3</td> <td>0.5</td> <td>0.8</td> <td>1.2</td> <td>2</td> <td>3</td> <td>4</td> </tr> <tr> <td>0.1</td> <td>0.1</td> <td>0.2</td> <td>0.3</td> <td>0.5</td> <td>0.8</td> <td>1.2</td> <td>2</td> </tr> </table>		0.5 3	3 6	6 30	30 120	120 400	400 1000	1000 2000	2000 4000	0.2	0.3	0.5	0.8	1.2	2	3	4	0.1	0.1	0.2	0.3	0.5	0.8	1.2	2	DRG. NO: <b>18</b> No of Pieces: <b>02</b>	
	30 120	120 315	315 1000	1000 2000	2000 4000																																										
+	3	4	6	8	11																																										
-	2	2	3	4	6																																										
0.5 3	3 6	6 30	30 120	120 400	400 1000	1000 2000	2000 4000																																								
0.2	0.3	0.5	0.8	1.2	2	3	4																																								
0.1	0.1	0.2	0.3	0.5	0.8	1.2	2																																								
DSG CH.		DESCRIPTION		DATE		APP.		SCALE: <b>1:2.3</b>		PAPER SIZE: A3		SHEET OF 1 of 1																																			



Third Angle Projection



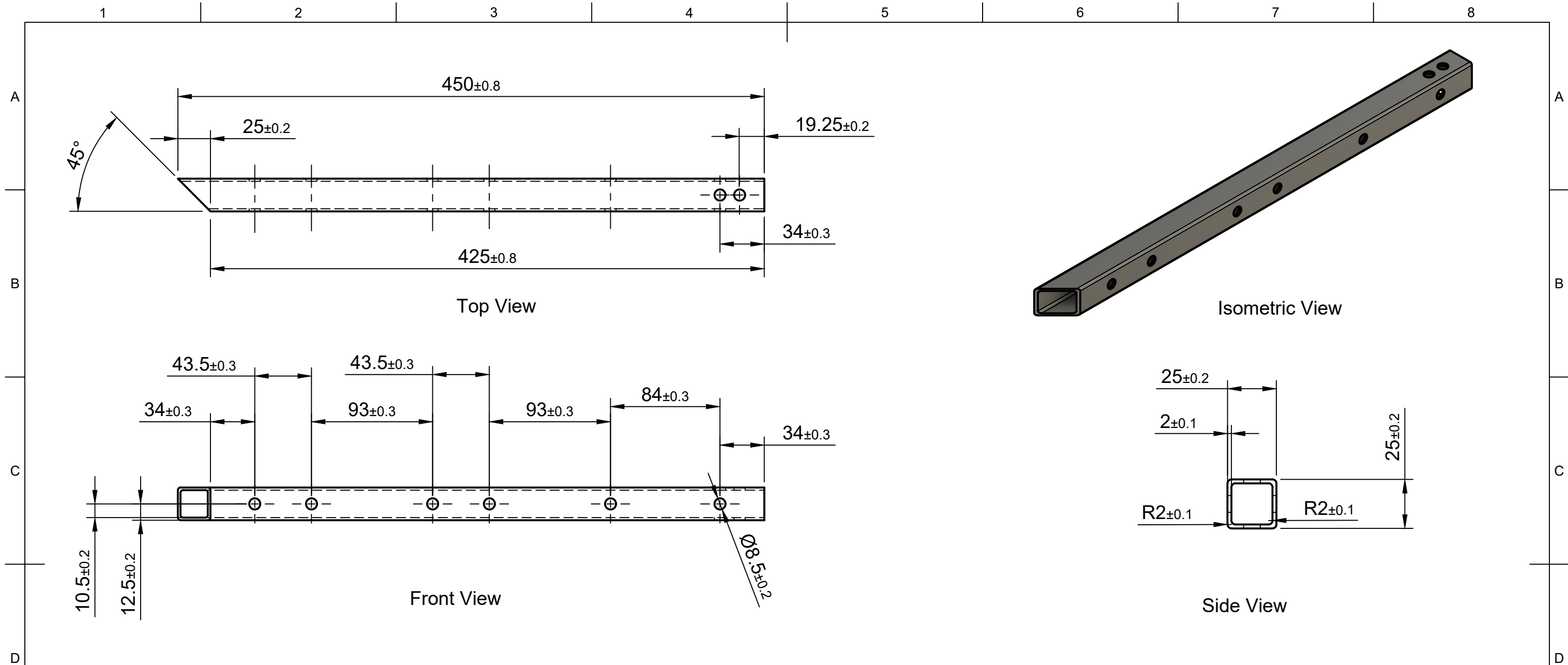

SR. NO.	PART NO	DESCRIPTION	QUANTITY	DIMENSIONS	MATERIAL
1.	<b>SEM20</b>	<b>Bar - 450</b>	<b>02</b>	<b>450 mm x 25 mm x 25 mm x 2 mm</b>	<b>Mild Steel</b>
Surface Finish: ✓ Tolerances: Mentioned In The Drawing UNLESS OTHERWISE SPECIFIED DIMENSIONS ARE IN MILLIMETRES		MATERIAL: Mild Steel WEIGHT: 0.360 Kg		DEBURR AND BREAK SHARP EDGES DO NOT SCALE DRAWING	
IF IN DOUBT, ASK		DRN		Jog Desai	03-12-2023
Default Tolerance table as per IS:2102		CHD		Jog Desai	03-12-2023
Welded Construction		Class		Machined and Formed	
APD		Jog Desai		03-12-2023	
DRG. NO: <b>20</b>		No of Pieces: <b>02</b>		AHMEDABAD UNIVERSITY SCHOOL OF ENGINEERING AND APPLIED SCIENCE	
MEC405 LEARNING FACTORY PROJECT		TITLE: <b>Bar - 450</b>		Part No: <b>SEM20</b>	
DSG CH.		DESCRIPTION		DATE	
APP.		SCALE: <b>1:3</b>		PAPER SIZE: A3	
				SHEET OF 1 of 1	



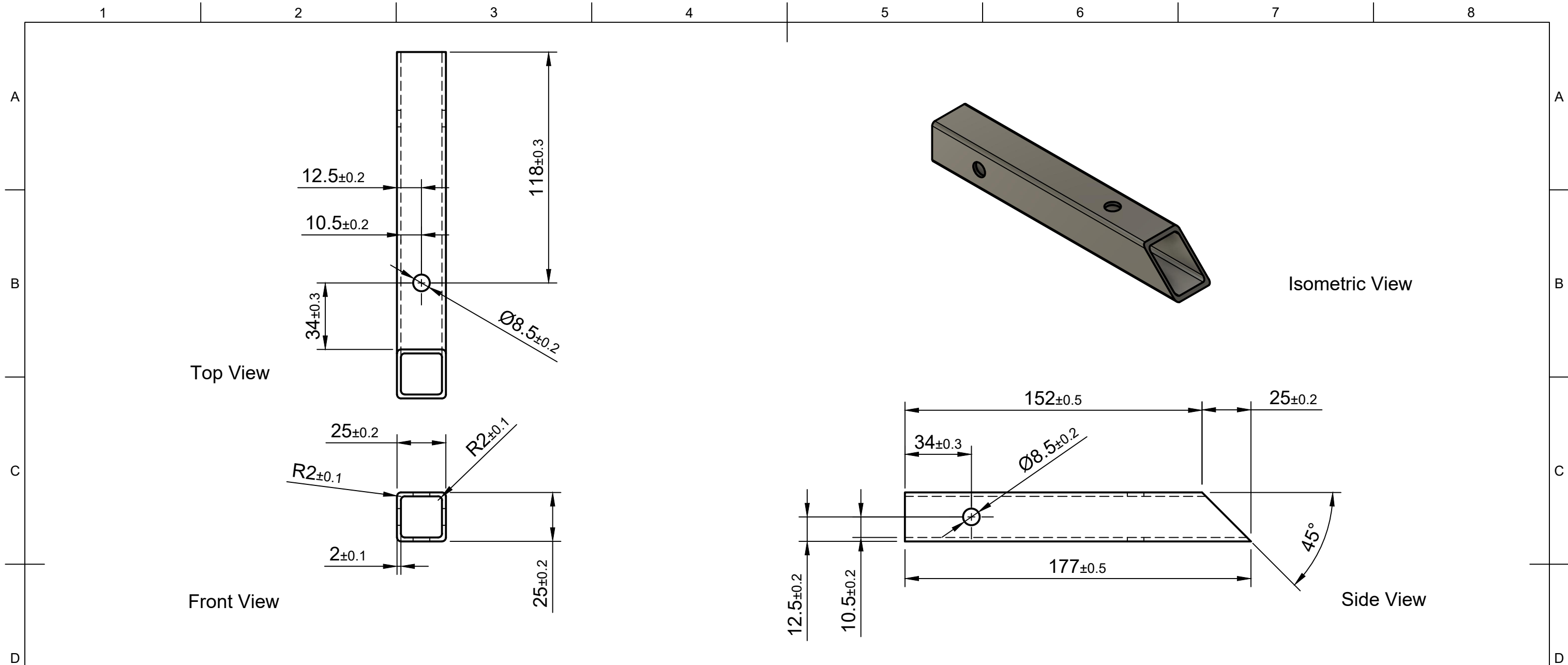

SR. NO.	PART NO	DESCRIPTION	QUANTITY	DIMENSIONS	MATERIAL
1.	<b>SEM21</b>	<b>Bar - 177</b>	<b>01</b>	<b>177 mm x 25 mm x 25 mm x 2 mm</b>	<b>Mild Steel</b>
Surface Finish: ✓ Tolerances: Mentioned In The Drawing UNLESS OTHERWISE SPECIFIED DIMENSIONS ARE IN MILLIMETRES		MATERIAL: Mild Steel WEIGHT: 0.155 Kg		DEBURR AND BREAK SHARP EDGES DO NOT SCALE DRAWING	
IF IN DOUBT, ASK		DRN		Jog Desai	03-12-2023
Default Tolerance table as per IS:2102		CHD		Jog Desai	03-12-2023
Welded Construction		Class		Machined and Formed	
APD		Jog Desai		03-12-2023	
DRG. NO: <b>21</b>		No of Pieces: <b>01</b>		AHMEDABAD UNIVERSITY SCHOOL OF ENGINEERING AND APPLIED SCIENCE	
MEC405 LEARNING FACTORY PROJECT		TITLE: <b>Bar - 177</b>		Part No: <b>SEM21</b>	
Third Angle Projection		SCALE: <b>1:2</b>		PAPER SIZE: A3	
DSG CH.		DESCRIPTION		DATE	
APP.		SCALE: <b>1:2</b>		SHEET OF 1 of 1	





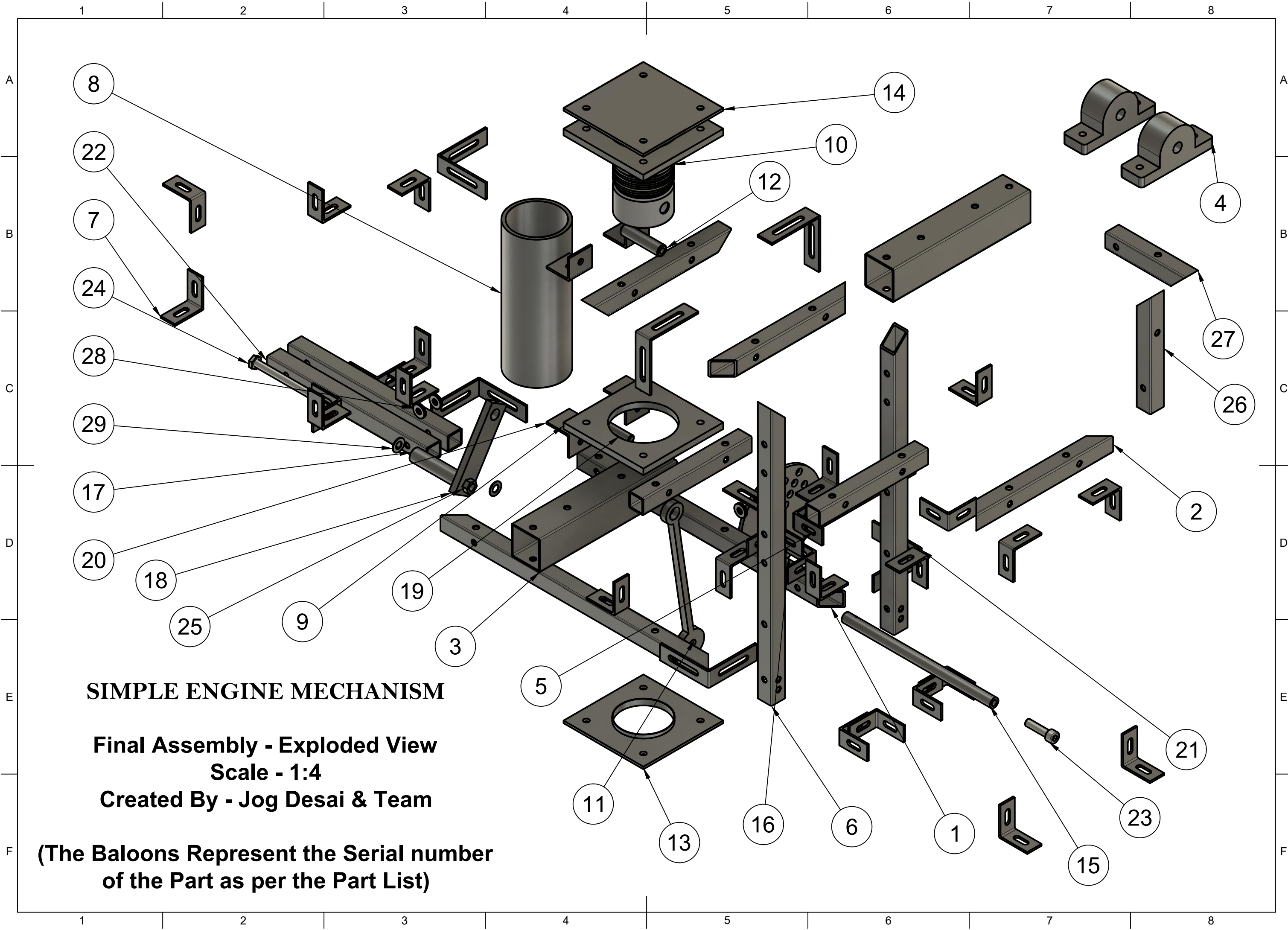

**SIMPLE ENGINE MECHANISM**

**Final Assembly - Exploded View**

**Scale - 1:4**

**Created By - Jog Desai & Team**

**(The Baloons Represent the Serial number of the Part as per the Part List)**

Parts List					
Item	Qty	Part Name	Part Number	Material	Mass
1	1	Bar - 470	SEM19	Steel	632.067 g
2	3	Bar - 240	SEM17	Steel	303.419 g
3	2	Bearing Stand	SEM15	Steel	718.111 g
4	2	Bearing	SEM23	Steel	1231.069 g
5	3	Bar - 190	SEM16	Steel	267.309 g
6	2	Bar - 450	SEM20	Steel	617.671 g
7	27	Clamp - 1 - Medium	SEM13	Steel	48.431 g
8	1	Cylinder Pipe	SEM01	Steel	2410.623 g
9	2	Cylinder Plate	SEM12	Steel	1043.335 g
10	1	Piston	SEM04	Steel	1534.751 g
11	1	Piston Rod	SEM03	Steel	257.227 g
12	1	Piston Pin	SEM09	Steel	77.749 g
13	1	Bottom Cover	SEM05	Steel	474.385 g
14	1	Top Cover	SEM06	Steel	682.374 g
15	1	Shaft	SEM08	Steel	337.399 g
16	1	Crank Disc	SEM02	Steel	562.734 g
17	1	Shaft handle holder	SEM11	Steel	137.611 g
18	1	Shaft handle plate	SEM07	Steel	275.542 g
19	1	Pin	SEM24	Steel	28.747 g
20	4	Clamp - 3 - Small	SEM10	Steel	65.151 g
21	7	Clamp - 2 - Big	SEM14	Steel	78.044 g
22	2	Bar - 280	SEM18	Steel	400.868 g
23	1	Allen bolt - M10	SEM25	Steel	37.461 g
24	1	Hex bolt - M10	SEM26	Steel	74.515 g
25	1	M10 - nut	SEM27	Steel	8.991 g
26	1	Bar -177	SEM21	Steel	234.04 g
27	1	Bar - 139	SEM22	Steel	179.153 g
28	8	M8 - Washer	SEM28	Steel	3.229 g
29	2	M10- Washer	SEM29	Steel	1.786 g